

Air Remote

Air Sync

User's Guide



Thank you for choosing Profoto

Thanks for showing us your confidence by investing in a Profoto Air Remote or Profoto Air Sync device. For more than three decades we have sought the perfect light. What pushes us is our conviction that we can offer even yet better tools for the most demanding photographers. Before our products are shipped we have them pass an extensive and strict testing program. We check that each individual product comply with specified performance, quality and safety. For this reason our flash equipment is widely used in rental studios in Paris, London, New York, and Tokyo and also the most rented flash all over the world.

Some photographers can tell just from seeing a picture, if Profoto equipment has been used

Professional photographers around the world have come to value Profoto's expertise in lighting and light-shaping. Our extensive range of Light Shaping Tools offers photographers unlimited possibilities for creating and adjusting their own light.

Every single reflector and accessory creates its special light and the unique Profoto focusing system offers you the possibility to create your own light with only a few different reflectors.

Enjoy your Profoto product!

Safety instructions



SAFETY PRECAUTIONS!

Do not operate the equipment before studying the instruction manual and the accompanying safety instructions, failure to do so may result in serious injuries.

Read and follow all safety instructions below carefully to avoid injuries or damages!

Make sure that Profoto Safety Instructions is always accompanied the equipment!

Profoto products are intended for professional use!

Do not place or use the equipment where it can be exposed to moisture, extreme electromagnetic fields or in areas with flammable gases or dust!

Do not expose the equipment to hasty temperature changes in humid conditions as this could lead to condensation water in the unit.

Operating temperature above -15 °C and below 50 °C.

Remove batteries during storage.

Equipment must only be serviced, modified or repaired by authorized or competent service personnel!



FINAL DISPOSAL

Equipment contains electrical and electronic components that could be harmful to the environment.

Equipment may be returned to Profoto distributors free of charge for recycling according to WEEE.

Follow local legal requirements for separate disposal of waste, for instance WEEE directive for electrical and electronic equipment on the European market, when product life has ended!

Table of Contents

System description	6
Profoto Air products	6
Profoto Air Remote	6
Profoto Air Sync	6
Profoto Air USB	6
Nomenclature	7
Functionality	8
Transmit/Receive mode selection	8
Channel selection	8
Synchronization	8
Group selection	8
Remote control	9
Master mode	9
Command confirmation	9
Test function	9
Fast mode	9
Connections	10
Batteries	10
Operating instructions	10
Synchronization	10
Generators with built-in Profoto Air receiver	10
Generators without built-in Profoto Air receiver	11
Fast mode	11
Generator control	11
Additional functions	12
Silent mode	12
Disable auto power	12
Factory settings	12
Technical data	13
Profoto Air Remote	13
Profoto Air Sync	13

System description

Profoto Air is a system for convenient wireless synchronization and remote control of flash generators. The Profoto Air system is operating on one of eight selectable radio channels on the 2.4 GHz radio frequency band, for world wide use.

Profoto Air products

All Profoto flash generators and lamp heads with Profoto Air inside can be controlled via the Profoto Air system. Products with integrated Profoto Air functionality are marked with the Profoto Air symbol.

6

Brief Instructions

Profoto Air Remote offers complete generator control and synchronization at your camera or in your hand, including flash energy and modeling light control. The device controls practically an infinite number of generators in up to six groups, either all at once in Master mode, or in individual groups.

Profoto Air Sync

Profoto Air Sync allows synchronization of practically an infinite number of generators, with the same high performance as Profoto Air Remote.

Profoto Air USB

Profoto Air USB connects your generator wirelessly to your PC or Mac. Together with Profoto Studio Air, it gives you full control of your studio flash generators and lamp heads. For more detailed information, please refer to the Profoto Studio Air User's Guide.



Nomenclature

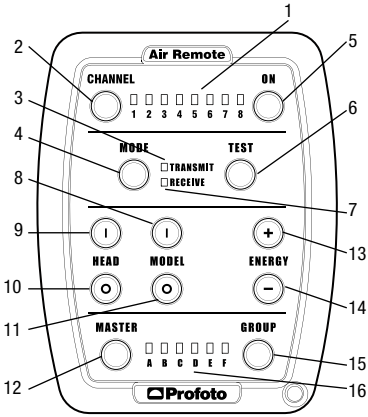

Profoto Air Remote

1. Channel Indicators
2. Channel Button
3. Transmit Indicator
4. Mode Button
5. On Button
6. Test Button
7. Receive Indicator
8. Model Button I
9. Head Button I
10. Head Button o
11. Model Button o
12. Master Button
13. Energy Button +
14. Energy Button -
15. Group Button
16. Group Indicators
17. Sync In Connector
18. Sync Out Connector
19. Hot Shoe Connector

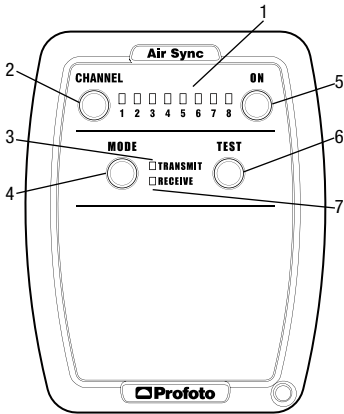

Profoto Air Sync

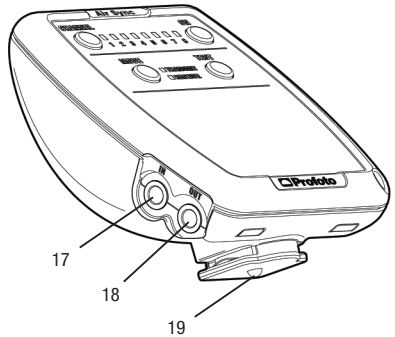

Connections

Functionality

Transmit/Receive mode selection

For generators that do not have a built-in Profoto Air receiver, the Profoto Air Remote or Profoto Air Sync device can be used as receiver. The Mode Button [4] is used to select Transmit or Receive mode.

Channel selection

Channel selection is used to select one of eight specific frequencies in the 2.4 GHz band. The frequencies are evenly spread over the entire frequency band, to optimize reliable functionality. The large number of radio channels makes it possible to select a channel that is not interfered by other photographers using Profoto Air, or by WLAN and Bluetooth devices and other radio equipment operating on the same widely used 2.4 GHz frequency band.

For radio synchronization and/or remote control of one or several generators, the same radio channel shall be set on all generators and Profoto Air devices.

Channel selection on the Profoto Air Remote and Profoto Air Sync devices is made with the Channel Button [2]. The Channel Indicator [1] corresponding to the selected radio channel (1–8) is illuminated.

Synchronization

All Profoto Air products that have the same radio channel set will be synchronized simultaneously.

Group selection

Groups are used to allow remote radio control of selected generator lamp heads. All lamp heads that are assigned to the same group will be controlled simultaneously. The lamp heads on a generator can be assigned to different groups. Lamp heads on different generators can be assigned to the same group.

Group selection enables remote control of a group of lamp heads, for example the background light. It also allows a large light bank with several lamp heads to be controlled as one light source.

Group selection on the Profoto Air Remote device is made with the Group Button [15]. The Group Indicator [16] corresponding to the selected radio group (A-F) is illuminated. The Master Button [12] is used to select all groups.

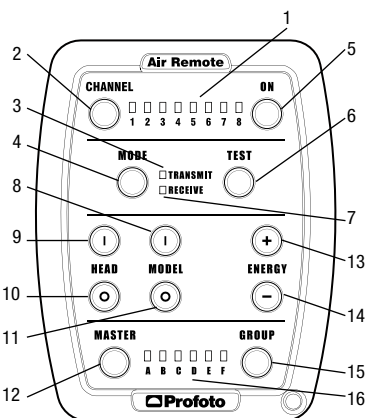

Remote control

Remote radio control is available for generators with built-in Profoto Air functionality.

For remote radio control, both the Channel and Group settings on the Profoto Air Remote device must match the Channel and Group settings of the lamp heads in the group.

With Profoto Air Remote it is possible to remotely control the power settings of the lamp heads in the group, to turn the lamp heads on/off and to turn the modeling light on/off.

The Head Button I [9] is used to turn on the flash lamp heads.

The Head Button O [10] is used to turn off the flash lamp heads.

The Model Button I [8] is used to turn on the modeling light.

The Model Button O [11] is used to turn off the modeling light.

The Energy Button + [13] is used to increase the energy level.

The Energy Button - [14] is used to decrease the energy level.

Press the Energy Button < 2 seconds to adjust the energy level in 1/10 f-stop increments.

Press the Energy Button > 2 seconds to adjust the energy level in 1 f-stop increments.

If the energy level of any flash lamp head in the group is in minimum or maximum position, all energy levels will remain unchanged; see section Command confirmation below.

Master mode

In Master mode, the same remote control command is sent to all Groups on the selected Channel.

With the Master Button [12] on the Profoto Air Remote device, all Groups are selected and will be affected by the remote control commands.

Command confirmation

If an energy level cannot be set by the generator as commanded, because a lamp head is in minimum or maximum position, the Profoto Air Remote device will make an acoustic sound to signal that the command was not executed. The energy level of all flash lamp heads in the group will remain unchanged.

Test function

The test function is used to test the synchronization function. The Test Button [6] is used to manually transmit a sync signal, verifying expected functionality.

Fast mode

The Profoto Air Remote and Profoto Air Sync devices deliver sync signals with a very short delay. In Fast mode, the delay is even shorter. Fast mode is only recommended when

working with very short camera shutter times, as the battery consumption is considerably higher. In Fast mode, the remote control functionality (available in Profoto Air Remote) is disabled and inoperative.

Connections

The Profoto Air Remote and Profoto Air Sync devices can be connected to the camera via the Hot Shoe Connector [19] or via a cable connected to the Sync In Connector [17].

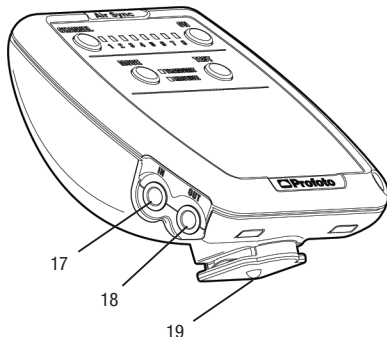

When the Profoto Air device is used in Receive mode, the device shall be connected to the generator's sync input socket via a cable connected to the Sync Out Connector [18].

Batteries

The Profoto Air Remote and Profoto Air Sync devices are powered by two standard AAA batteries.

Operating instructions

Synchronization

This section applies to both Profoto Air Remote and Profoto Air Sync.

Generators with built-in Profoto Air receiver

1. Set the generator to synchronization via radio.
2. Connect the Profoto Air Remote or Profoto Air Sync device to the camera, via the Hot Shoe Connector [19] or via the Sync In Connector [17].
3. Press and hold down the On Button [5] to turn on the device.
4. Verify that the Transmit Indicator [3] is illuminated.
5. Press and hold down the Channel Button [2] until the desired Channel Indicator [1] is illuminated. The selected channel shall be the same as the generator's radio channel setting.
6. Press the Test Button [6] to verify that the functionality is as expected.

Generators without built-in Profoto Air receiver

1. Connect one Profoto Air Remote or Profoto Air Sync device (Receiver) to the generator, via a cable from the Sync Out Connector [18] on the device to the sync input socket on the generator.
2. Press and hold down the On Button [5] to turn on the Profoto Air device.
3. Press and hold down the Channel Button [2] until the desired Channel Indicator [1] is illuminated.
4. Press the Mode Button [4] and verify that the Receive Indicator [7] is illuminated.
5. Connect another Profoto Air Remote or Profoto Air Sync device (Transmitter) to the camera, via the Hot Shoe Connector [19] or via the Sync In Connector [17].
6. Press and hold down the On Button [5] to turn on the Transmitter device.
7. Verify that the Transmit Indicator [3] is illuminated.
8. Press and hold down the Channel Button [3] until the same Channel Indicator [1] as on the Receiver device is illuminated.
9. Press the Test Button [6] on the Transmitter device to verify that the functionality is as expected.

Fast mode

Fast mode is used when an extra short sync signal delay is required.

1. To enter Fast mode, press and hold down the Mode Button [4] for 7 seconds, until the Transmit Indicator [3] starts to blink.
2. To exit Fast mode, press the Mode Button [4] once.

Generator control

This section applies to Profoto Air Remote. Remote generator control is possible for generators with built-in radio control functionality.

1. Press and hold down the On Button [5] to turn on the device.
2. Verify that the Transmit Indicator [3] is illuminated.

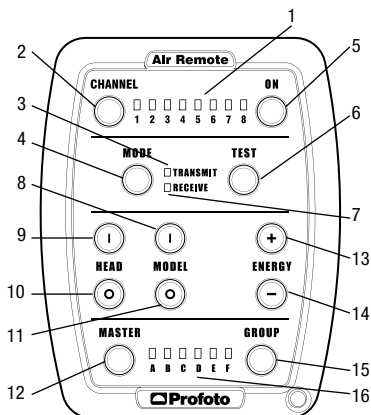

3. Press and hold down the Channel Button [2] until the desired Channel Indicator [1] is illuminated. The selected channel shall be the same as the generator's radio channel setting.
4. Press and hold down the Group Button [15] until the desired Group Indicator [16] is illuminated. The selected group shall be the same as the generator's radio group setting.
5. To select all groups, press the Master Button [12].
6. Press the Head Buttons [9] and [10] to turn on/off all flash lamp heads in the selected group.
7. Press the Model Buttons [8] and [11] to turn on/off the modeling light in the selected group.
8. Use the Energy Buttons [13] and [14] to increase/decrease the energy level of the selected group:

Press the Energy Button < 2 seconds to increase/decrease in 1/10 f-stop increments.

Press the Energy Button > 2 seconds to increase/decrease in 1 f-stop increments.

Additional functions

Silent mode

Turn of the device. Press and hold down Head 0 Button and On Button to turn off silent mode. Silent mode settings will automatically be reset when turning of the device.

Disable auto power

Turn of the device. Press and hold down Energy + Button and On Button to turn off auto power. Disable auto power settings will automatically be reset when turning of the device.

Factory settings

Turn of the device. Press and hold down Test Button and On Button to reset to factory settings.

Technical data

Profoto Air Remote

Profoto Air Sync

Specifications	
Frequency band	2.4 GHz
Separate radio channels	8
Group/radio channels	6
Range	Range Up to 300 m (1000 ft)
Battery type	2 x AAA
Typical battery lifetime Transmit mode Fast/Normal	10 hrs/140 hrs
Typical battery lifetime Receive mode	30 hrs
Sync delay, Fast/Normal mode	200 μ s/465 μ s
Antenna type	Integrated
Auto power off	30 min of inactivity
Sync signal in	ISO 518 hot shoe and 3.5 mm phone plug
Sync signal out	3.5 mm phone plug
Measurements	
Dimensions	70 x 50 x 40 mm (2.7 x 1.9 x 1.6 in)
Weight	40 g/70 g (1.4 oz/2.5 oz)

All data are to be considered as nominal and Profoto reserves the right to make changes without further notice.

Profoto AB
P.O. Box 2023
SE-128 21 Skarpnäck
SWEDEN

Phone +46 8 447 53 00
info@profoto.com
www.profoto.com

 **Profoto**
The Light Shaping Company